

HOT FOOD TABLES ELECTRIC



Standard Features

- Heavy duty stainless steel body
- Die-stamped 12" x 20" openings
- Galvanized legs with adjustable bullet ends
- Adjustable stainless steel undershelf
- Individually controlled infinite switches for each compartment
- Red indicator light that stays on while in use
- Wells are 8" deep and lined with galvanized steel
- Each compartment is fully insulated on all sides and bottom with 1" thick insulation

Model #	Well Openings	Volts	Wattage	Amps	Dimensions	Gross Weight
HFT-2-120	2	120V	1500W	12.5	33"W X 31"D X 34.25H	89.5 lbs.
HFT-3-120	3	120V	2250W	18.75	45.8"W X 31"D X 34.25H	112.5 lbs.
HFT-4-120	4	120V	3000W	25	63.75"W X 31"D X 34.25H	141.5 lbs.

Plan View

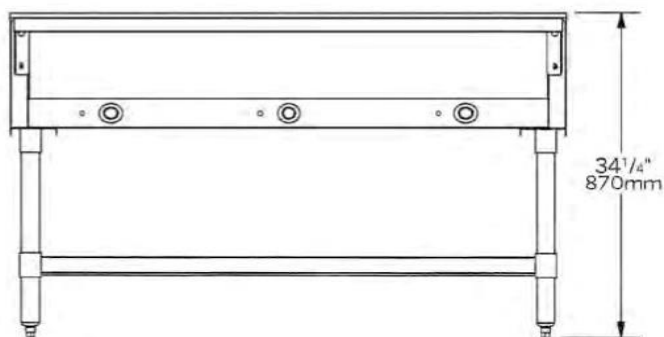

FRONT VIEW

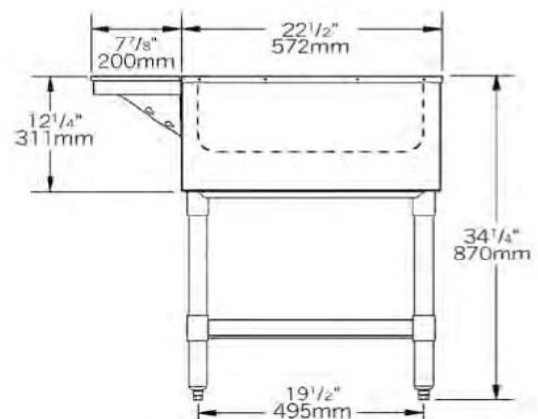

SIDE VIEW