

Project Name: _____ AIA#: _____

Model #: _____ Location: _____

SIS#: _____ Item #: _____ Quantity: _____



60 Quart Planetary Floor Mixers

**The Perfect Mix of Value,
Performance & Durability**

This award-winning mixer features 3 fixed speeds and front-mounted touch pad controls with a digital timer.



Model

SP60

Standard Features

- Powerful 3 HP custom built motor
- Gear-driven, high-torque transmission
- Heat-treated hardened steel alloy gears & shafts
- Three fixed speeds
- Permanently lubricated transmission
- Thermal overload protection
- Front-mounted touch pad controls with 60-minute digital timer and last-batch recall
- Removable stainless steel, interlocking bowl guard with built-in, fully welded ingredient chute
- Safety interlocked bowl lift
- Rigid cast iron body
- Industry standard #12 attachment hub
- NSF approved enamel gray paint
- 6-foot cord and ground plug

Standard Accessories/Attachments

- 60 qt stainless steel bowl (#304 series)
- Aluminum flat beater
- Stainless steel wire whip
- Aluminum spiral dough hook
- Non-slip rubber feet
- Bowl truck

Warranty

- *Two years parts and labor*

Optional Accessories/Attachments

- Seismic flange kit
- Polycarbonate splash shield insert
- Slicer/shredder/grater for #12 hub
- Meat grinder for #12 hub
- Meat tenderizer for #12 hub
- Strip cutter for #12 hub
- Stainless steel flat beater
- Stainless steel whip
- Bowl scraper
- Additional bowl truck
- 30 qt. adapter kit
- 40 qt. adapter kit
- Extended warranty

To select options see back



Approved by: _____ Date: _____

2153 Dryden Rd., Dayton, OH 45439 | 937-299-5493 | 800-347-5423 | Fax: 937-299-4147 | www.globefoodequip.com

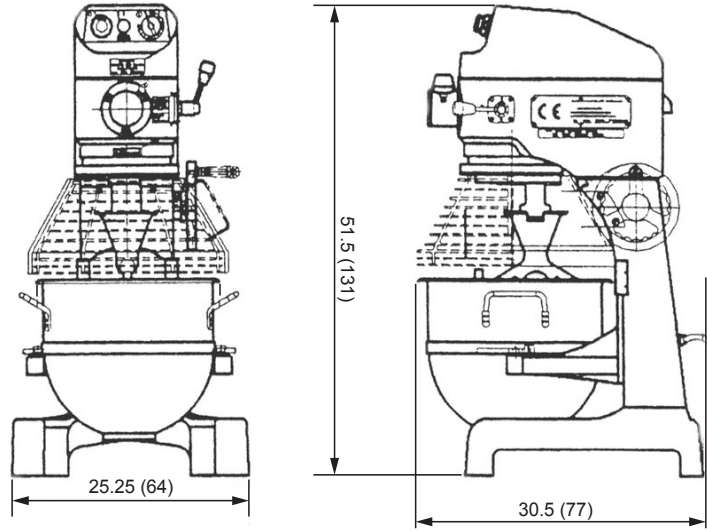

Drawings available through KCL at www.kclcad.com.

SPECIFICATIONS

Model	Motor	Volts	Amps	Transmission Type	Capacity	Controls	Agitator Speeds (RPMs)			Attachment Speeds (RPMs)		
							1st	2nd	3rd	1st	2nd	3rd
SP60	3 HP	220/60/1* 208/60/3*	23 9	Gear	60 qt / 57 liter	Front-mounted digital controls & timer	73	120	267	49	82	181

Cord & Plug: Attached 6-foot flexible 3-wire cord with molded plug fits a grounded receptacle. Single phase NEMA L6-30P (Ⓢ) Three phase NEMA L15-20P (Ⓢ)

**Specify voltage when ordering.*

DIMENSIONS | SHIPPING INFORMATION

Reinforced carton for shipping. The weight and dimensions of this reinforced carton are included below and may vary from shipment to shipment. **This product ships on a pallet. Freight class 85.**

Model	Overall Dimensions	Net Weight	Shipping Dimensions	Shipping Weight
SP60	25.25" W x 30.5" D x 51.5" H (64 cm x 77 cm x 131 cm)	572 lbs (260 kg)	46" W x 48" D x 65" H (122 cm x 122 cm x 165 cm)	700 lbs (317.5 kg)

Mixer is constructed of a rigid cast iron body with controls and 60-minute digital timer with last-batch recall. Mixer has 3 HP custom built motor with overload protection and gear-driven, high-torque, permanently lubricated transmission consisting of heat-treated hardened steel alloy gears and shafts. Mixer comes with 60 qt. stainless steel bowl, aluminum flat beater, stainless steel bowl truck and wire whip, aluminum dough hook and non-slip rubber feet. Interlocked with removable stainless steel bowl guard with fully welded ingredient chute. Mixer has #12 attachment hub and interlocked bowl lift. Mixer is NSF and ETL listed. Two-year parts and labor warranty.

OPTIONAL MIXER ACCESSORIES AND HUB ATTACHMENTS

- MIXER:**
- XXSEISMIC KIT-MD** Seismic kit
 - XXBGSHIELD-60** Bowl guard shield
 - XXBOWL-60** 60 qt stainless steel bowl
 - XXBEAT-60** Alum. flat beater
 - XXBEAT-60SS** S/S flat beater
 - XXHOOK-60** Alum. dough hook
 - XXWHIP-60** S/S wire whip
 - XXHDWHIP60-4** Heavy-duty 4 mm S/S wire whip
 - XXHDWHIP60-5** Heavy-duty 5 mm S/S wire whip
 - XXSCRIP-60** scraper with mounting kit
 - XXACC30-60** Adapter kit - 30 qt bowl, hook, beater and whip
 - XXACC40-60** Adapter kit - 40 qt bowl, hook, beater and whip
 - XBTRUCK-60** 60 qt heavy-duty bowl truck
- HUB:**
- XVSGH** 9" Slicer/Shredder/Grater housing only (no plates included-must select from plates listed on this sheet)
 - XASP** Adjustable slicing plate (veg. only)
 - XPH** Plate holder
 - L00670** Meat Tenderizer attachment
 - L00783** Strip Cutter attachment
- Shredding Plates:**
- XSP332*** 3/32" (2.3 mm)
 - XSP316*** 3/16" (4.7 mm)
 - XSP14*** 1/4" (6.3 mm)
 - XSP516*** 5/16" (7.9 mm)
 - XSP12*** 1/2" (12.7 mm)
 - XGP*** Grating plate
 - *Only 1 plate holder required**
 - XMCA-SS** Meat grinder assembly (Polished stainless steel cylinder, worm gear, ring, and s/s pan. Includes knife, 3/16" plate, and pusher)
 - XXCK** Chopper knife for XMCA-SS
- Chopper Plate Sizes Available:**
- CP02-12** 1/16" (2 mm)
 - CP04-12** 5/32" (4 mm)
 - CP05-12** 3/16" (5 mm)
 - CP06-12** 1/4" (6 mm)
 - CP08-12** 5/16" (8 mm)
 - CP10-12** 3/8" (10 mm)
 - CP12-12** 1/2" (12 mm)
 - CP14-12** 9/16" (14 mm)
 - CP16-12** 5/8" (16 mm)
 - CP18-12** 11/16" (18 mm)
 - CP00-12** Stuffing plate
 - XST12** 1/2" Stuffing tube (mutton)
 - XST34** 3/4" Stuffing tube (pork)
- FACTORY INSTALLED OPTION:**
- XXCORR-60** Correctional package, includes tamper resistant external fasteners.
- EXTENDED WARRANTY**
- SP-XD4060** Extended warranty for SP60 mixer, extends factory warranty to 3 years. **Available only at time of purchase.**