

## KD Utility Cart

Model BC340KD

Item No. \_\_\_\_\_

Specifier Identification No. \_\_\_\_\_

Model No. \_\_\_\_\_

Quantity \_\_\_\_\_

### Features & Benefits



- Sturdy, strong and durable, this cart is designed to handle a wide variety of transporting needs from the receiving dock to the front of the house.
- Use to store equipment and supplies, deliver room service or tear down a banquet room. Versatile workhorse moves easily from table set up to bussing service, delivering prepared foods to food bars, coffee service, or transporting catering supplies off the delivery truck.
- Ships "knocked down" to minimize shipping costs, yet easy to assemble and ready to use in minutes.
- Load capacity - 400 lbs. (181 kg).
- Three each polypropylene shelves are durable, stain resistant and easy to clean plus lightly textured to reduce sliding. Each shelf holds one full size dish rack or two standard size bus boxes.
- Raised marine rails around each shelf prevent items from slipping off.
- Generous 11 3/4" (30 cm) open spacing between shelves speeds up loading and unloading.
- Aluminum uprights between shelves ensure optimum sturdiness and stability and are rust-resistant.
- Two ergonomic polypropylene handles are included with each cart.
- Four non-marking, powder coated steel, 5" (12,7 cm) swivel casters without brake are durable and strong and offer quiet, easy transportation.
- Optional accessories include Single Shelf Panel Set, a removable 8 gallon (30,3L) Trash Container and 2 1/2 gallon (9,5L) Silverware Holder. Shelf panels must be added at time of assembly.
- Easy to assemble. Directions included with each cart. Use plastic mallet only.
- Available in two colors, Speckled Gray (480) and Black (110).



BC340KD



BC340KD Shown with  
Optional Shelf Panel Sets



Shelf Panel Set  
(includes 1 Side Panel  
and 2 End Panels)



2.5 Gallon (9,5 L)  
Silverware Holder



8 Gallon (30,3 L) Trash Container

# KD Utility Cart

Model BC340KD

Item No. \_\_\_\_\_

Specifier Identification No. \_\_\_\_\_

Model No. \_\_\_\_\_

Quantity \_\_\_\_\_

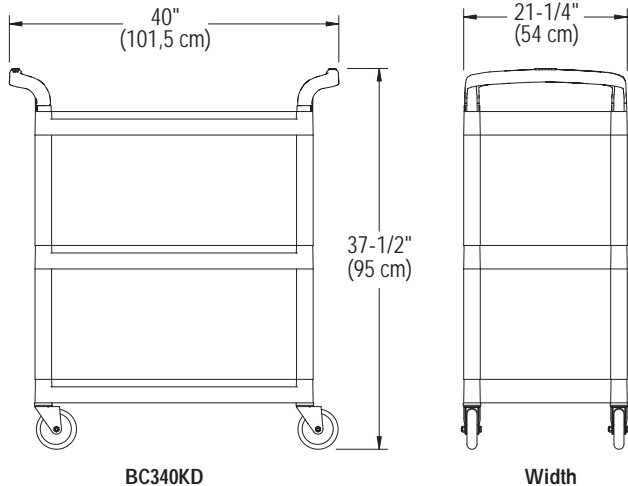

## Specifications

Dimension Tolerance: +/- 1/4" (0,64 cm)

Code	Description	Load Capacity	Inside Shelf Dimensions L x D x H*	Exterior Dimensions L x D x H (with both handles)	Case lbs./cube Kg/m <sup>3</sup>
BC340KD	KD Utility Cart - Open Sides	400 lbs. (181 Kg.)	31 1/2" x 20 1/2" x 11 3/4" (80 x 52 x 29,8 cm)	40" x 21 1/4" x 37 1/2" (101,5 x 54 x 95 cm)	39 (6,72) 17,7 (0,19)

\*Height is between shelves.

## Optional Accessories

- 8 Gal. (30,3 L) Trash Container  BC331KDTC
- 2.5 Gal. (9,5 L) Silverware Holder  BC33KDSH
- Single Shelf Panel Set  BC340KDP

## Standard Cart and Shelf Panel Set Colors

- Speckled Gray (480)
- Black (110)

## Trash Container and Silverware Holder Color

- Black (110)

## Architect Specs

The KD Utility Cart shall be Cambro Model BC340KD. It shall be constructed of polypropylene shelves and anodized aluminum shelf supports. It shall have two each polypropylene ergonomic handles. It shall be able to transport up to 400 lb. (181 kg). Each shelf shall have a slip-resistant, textured surface and raised edges on all four sides to prevent contents from sliding off. It shall have open sides with generous 11 3/4" (30 cm) spacing between shelves to speed up loading and unloading. It shall have four each 5" (12,7 cm) powder coated steel, swivel casters, all without brake. It shall be available with an optional Single Shelf Panel Set in Speckled Gray (480) or Black (110), an 8 gallon (30,3 L) Trash Container and a 2 1/2 gallon (9,5 L) Silverware Holder, both available in Black (110) only. It shall require assembly and shall be available in 2 colors.